

# Whiz Bed - assembly

**Harvey Norman**

## Bolt Pack List

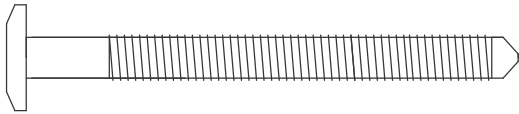

Silver Bolt 60mm - 4 of

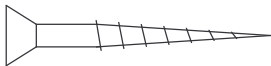

Brass screw 35mm - 4 of



4mm Allen Key - 1 of

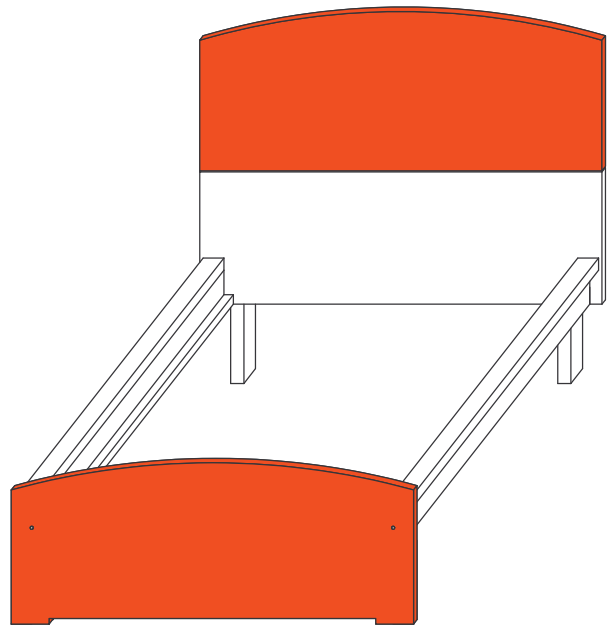

## Assembly Instructions

1/ Attach both side rails to foot end using the 60mm silver bolts

\*\*\* IMPORTANT \*\*\*

Ensure the metal dowel (illustrated) is level such that the bolt will go straight in. If it is not level, the bolt may cross thread.

2/ Now connect the head board to the side rails

3/ Place base board inside side rails and connect with 35mm screws

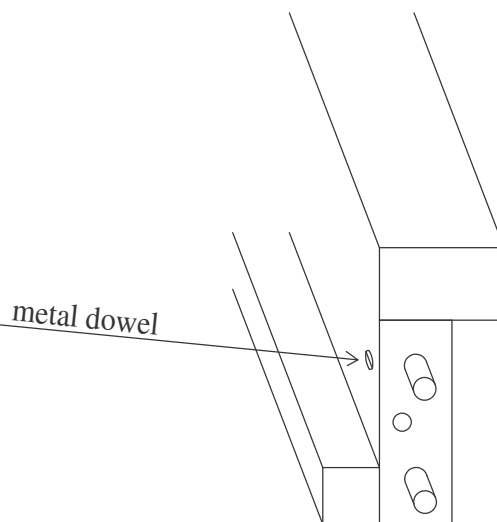



[www.modularfurniture.com.au](http://www.modularfurniture.com.au)

ABN 79 007 709 748

27 Wilson Street, Royal Park, South Australia 5014 Tel (08) 8447 3088 Fax (08) 8341 1398

### **Important Furniture Care**

Here are just a few ideas to help keep your Modular Furniture product looking good for many years to come.

Dust with a soft clean cloth or feather duster.

Wipe with a clean damp cloth to remove minor marks.

Spillages especially alcohol should be wiped off immediately with a damp cloth.

Protect your furniture with heat resistant placemats for all hot food and beverages.

Do not expose timber to direct sunlight or extremes of humidity.

Do not conceal the tops of your furniture with glass covers. This can result in sweating of the timber and peeling of the stain may occur.

Do not use general household cleaning products that contain silicones or abrasive polishers.

Do not allow hot or abrasive items in contact with your surfaces.

Do not allow liquids or damp cloths to remain in contact with the furniture's surfaces.

Doors and drawers are squarely fitted in our factory. Ensure your unit sits on a level surface for smooth operation.

Periodically check & tighten screws as necessary. Bed Slats should be alternated from centre to end every six months to extend life. Solid slats and bases should be flipped over at that time.

Timber is a natural product, so variances in colour, shade and grain will occur due to ageing. A small amount of timber movement is also considered natural. In the event of damage, please contact your retailer or our factory for advice.

### **Warranty**

Modular Furniture Pty Ltd guarantees to make good by repair or replacement (at its discretion), any manufacturing defect for a period of 5 years from the original date of purchase to the original owner.

The identification label placed on the back or bottom of each item of furniture is used to validate the purchase date and therefore should not be removed.

This is provided that care instructions have been followed, the product has not been altered or repairs attempted by an unauthorised person, and any defect is not the result of normal wear and tear, improper use, mistreatment, negligence, or an accident, and is not a natural characteristic of the material used.

Should the item require return to the place of manufacture, costs of transportation are not covered under this warranty. On occasion Modular Furniture Pty Ltd may request return of goods for inspection prior to acceptance of any warranty claim. At its discretion Modular Furniture Pty Ltd may replace items either in part or full as deemed necessary. All endeavours will be made to match items replaced with that of the original but no guarantee can be given due to changes in the supply of goods or manufacturing processes, or circumstances beyond its control. No extensions apply to the warranty period for any product repaired or replaced.

This warranty applies to all furniture manufactured and sold by Modular Furniture Pty Ltd and distributed throughout Australia after 1<sup>st</sup> July 2006

Thank you for your purchase

For more information on our products visit our Website at [www.modularfurniture.com.au](http://www.modularfurniture.com.au)

Proud Members of the Furnishing Industry Association of Australia Limited

